

► SPECIFICATIONS

# 9 Tonne Front Tip

MACH590

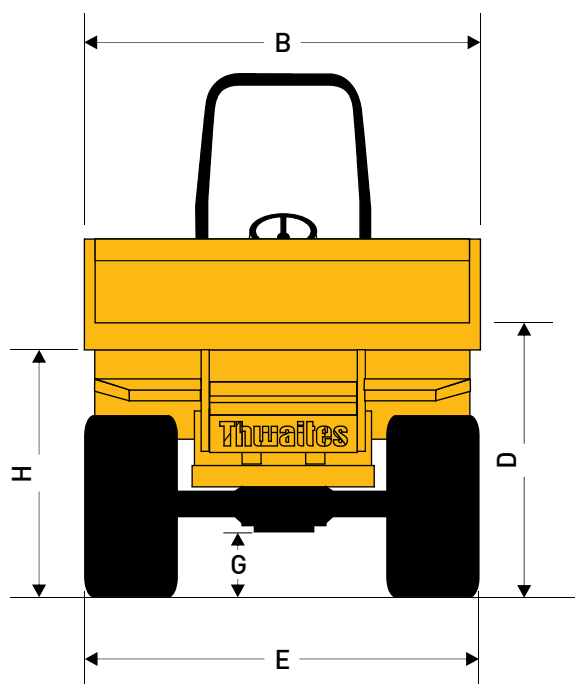
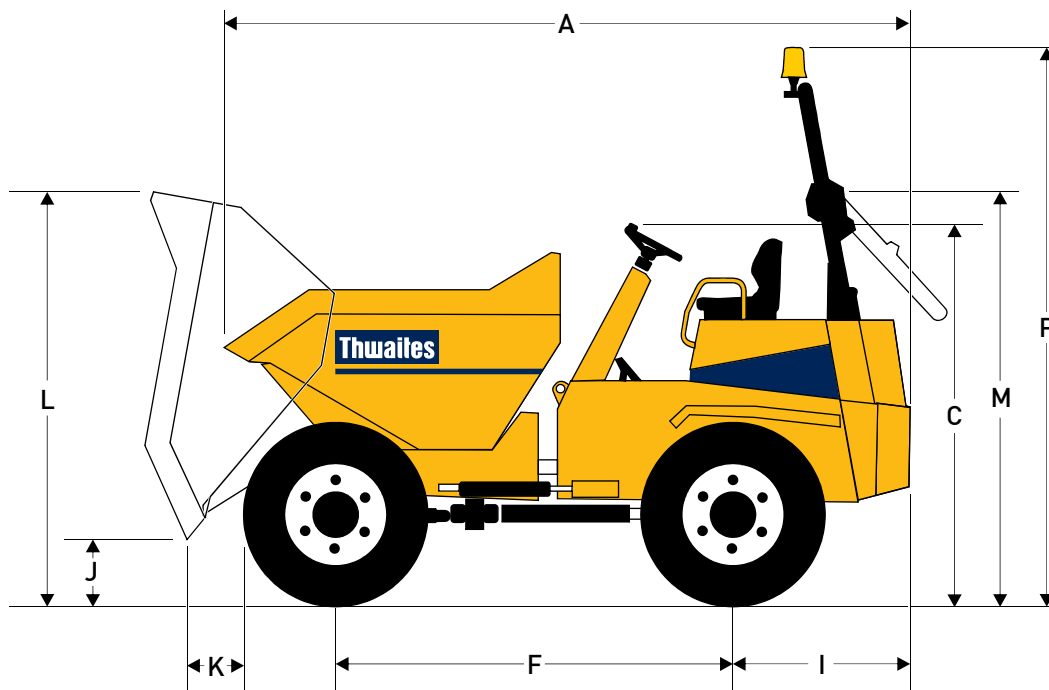

**Dimensions  
(mm)**

A	4635
B	2485
C	2440
D	1740
E	2440
F	2615
G	447
H	1975
I	1220
J	436
K	642
L	2840
M	2555
P	3335

# 9 Tonne Front Tip

**MACH590**

<b>Capacities</b>	Max safe load	9000kg
	Heaped	4600 litres
	Struck	3830 litres
	Water	2155 litres

## Engine

Perkins 1104 D series, 70kW/94 bhp (gross) at 2200 rpm, 4-cylinder turbo-charged water-cooled direct-injection diesel. Max. torque 392 Nm (289 lb ft). Hour meter, battery isolation switch and heavy-duty cyclonic air cleaner positioned within the lockable engine compartment. Tier 3-/Stage IIIA-compliant.

## Noise Levels

Operator's ear 84 LpA, airborne sound power level 102 LwA (to 2000/14/EC).

## Transmission

Torque converter four speed forward and reverse Powershuttle transmission with column mounted directional control lever and heavy duty gear driven transfer box.

<b>Speeds</b>	Forward and Reverse	
	1	5.4km/h (3.4 mph)
	2	8.7km/h (5.4 mph)
	3	16.4km/h (10.2 mph)
	4	30.1km/h (18.7 mph)

<b>Tyres</b>	500/60 x 22.5
	Track grip tread
	Load/Speed Index 149 A8

## Brakes and Axles

Twin-circuit totally enclosed multiplate oil-immersed discs mounted on both axles with automatic adjustment for wear. Hand-operated parking brake. Heavy-duty axles with epicyclic reduction and fully floating halfshafts.

## Kinglink Chassis

Front and rear chassis constructed from deep section folded steel plate, with three-point Kinglink giving centre articulation and oscillation for better stability, traction and extra safety on site. Remote greasing point provided for lubrication of top Kinglink articulation pin.

## Skip

Hydraulically operated, 6 mm steel base plate, fully welded, mouth and sides of skip reinforced with box sections giving greater strength to minimise skip damage. No material traps. Optional abrasion resistant steel plate (AR400) for skip base, rear and front panel sections.

## Seating & Controls

Adjustable suspension seat, accessible from both sides. Audible warning device for handbrake in 'on' position. Electric horn. Large pedal pads with handbrake and hydraulic controls ready to hand. Super bright warning lights for all critical functions.

## Service Access

Lockable three-sided cover opens to provide easy access from ground level to engine service points, all located on the same side. Rear chassis panel can be hinged back on retainers. Additional service access door incorporates the battery. Moulded diesel and hydraulic tanks positioned low in the chassis side members, permitting access to the filler caps from ground level.

## Electrics

Wiring harness contained within conduits and all electrical components water resistant to IP65/67 standards.

## Steering and Hydraulics

Hydraulic priority power steering. Filter mounted on the top of the tank accessible from ground level. Hydraulic test point fitted as standard.

<b>Tank Capacities</b>	Fuel	70 litres
	Hydraulic	70 litres

<b>Shipping Cube</b>	28.1 m <sup>3</sup> (without ROPS)
----------------------	------------------------------------

<b>Unladen Weight</b>	4650 kg (Max)
-----------------------	---------------

<b>Clearance Diameter</b>	14m
---------------------------	-----

<b>Towing Bracket</b>	Standard
-----------------------	----------

## ROPS

For the UK and other markets where it is a legal requirement, a folding ROPS frame hinged is fitted as standard.

## Optional Extras

Beacon. Full road lighting equipment. UK road equipment. Anti-theft device. Height-adjustable towing brackets.

Distributor



Thwaites Ltd. Leamington Spa, Warwickshire CV32 7NQ, England  
 Tel +44 (0)1926 422471 Fax +44 (0)1926 337155  
 www.thwaitesdumpers.co.uk



We reserve the right to change all specifications without prior notice.  
 Printed in England 02/2017